

3 Phase Voltage Transformer Model 3VTN460

The 3VTN transformers are designed for line to neutral operation. They are encased in a thermoplastic case with the cores and windings encapsulated in resin. The assembly consists of three separate transformers with all terminals accessible.

Frequency: 50/60Hz

Standard Secondary Voltage: 120 VAC Line to Neutral

Insulation Level: 600 Volt, 10kV BIL Full Wave

Accuracy Class 60Hz: 0.6W, 1.2 X (Per Phase)

Accuracy Class 50Hz: 0.5@ 10VA, 1.0 @ 20VA

Thermal Rating 60Hz: 150VA @ 30 C. Amb., 100VA @ 55 C. Amb.

Thermal Rating 50Hz: 125VA @ 30 C. Amb., 75VA @ 55 C. Amb.

Terminals are No. 8-32 screws into 1/2" deep brass inserts with lock washer and flat washers.

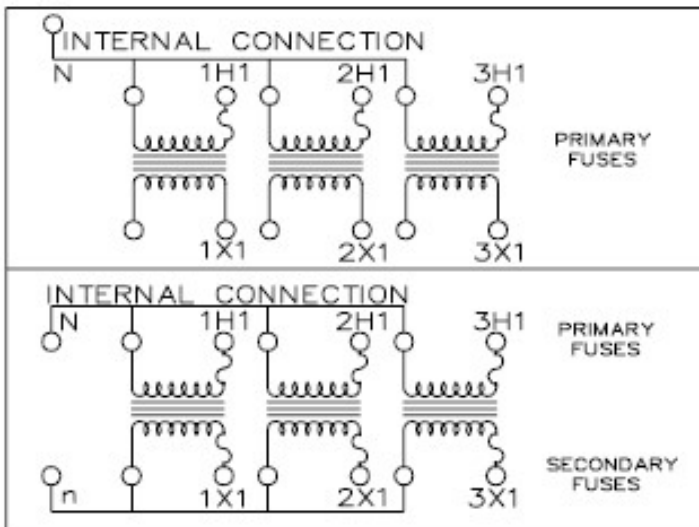

Shown with optional Primary and Secondary fuses.

EI Part Number (No fuses)	Primary Fuse Only	Primary and Secondary Fuses	Line-to-Neutral Voltage	Turns Ratio	Primary Fuse Rating	Secondary Fuse
3VTN460-069	3VTN460-069F	3VTN460-069FF	69.3:120	0.58:1	5A	1.6A
3VTN460-120	3VTN460-120F	3VTN460-120FF	120:120	1:1	4A	1.6A
3VTN460-240	3VTN460-240F	3VTN460-240FF	240:120	2:1	2A	1.6A
3VTN460-277	3VTN460-277F	3VTN460-277FF	277:120	2.31:1	2A	1.6A
3VTN460-300	3VTN460-300F	3VTN460-300FF	300:120	2.5:1	1.5A	1.6A
3VTN460-346	3VTN460-346F	3VTN460-346FF	346:120	2.88:1	1.5A	1.6A

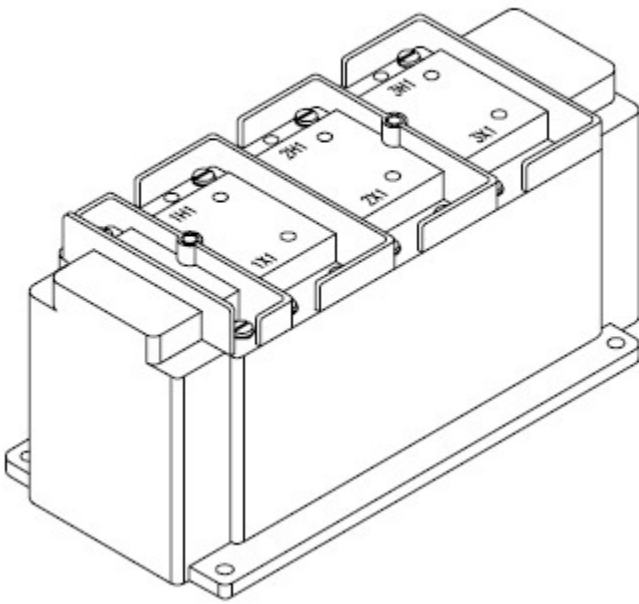

- These transformers are designed for Line to Neutral operation.
- Spacing between live parts per U.L. 1558.
- Primary fuses are current limiting, 200kA interrupting capacity, typically (class CC) KTK—R type.
- It is desirable to use a 1.6 amp BBS type or equal fuse in the secondary to protect the transformer.
- Only ground N/n terminals if source is 3 phase, 4 wire effectively grounded.
- The transformer has a clear plastic cover.
- Other ratios available, please contact us to assist your specific needs.

Rev A 09 06 2024